

Genie®

Operator's Manual

with Maintenance Information

Fourth Edition
Second Printing
Part No. 1000033

GS™-2032

GS™-2632

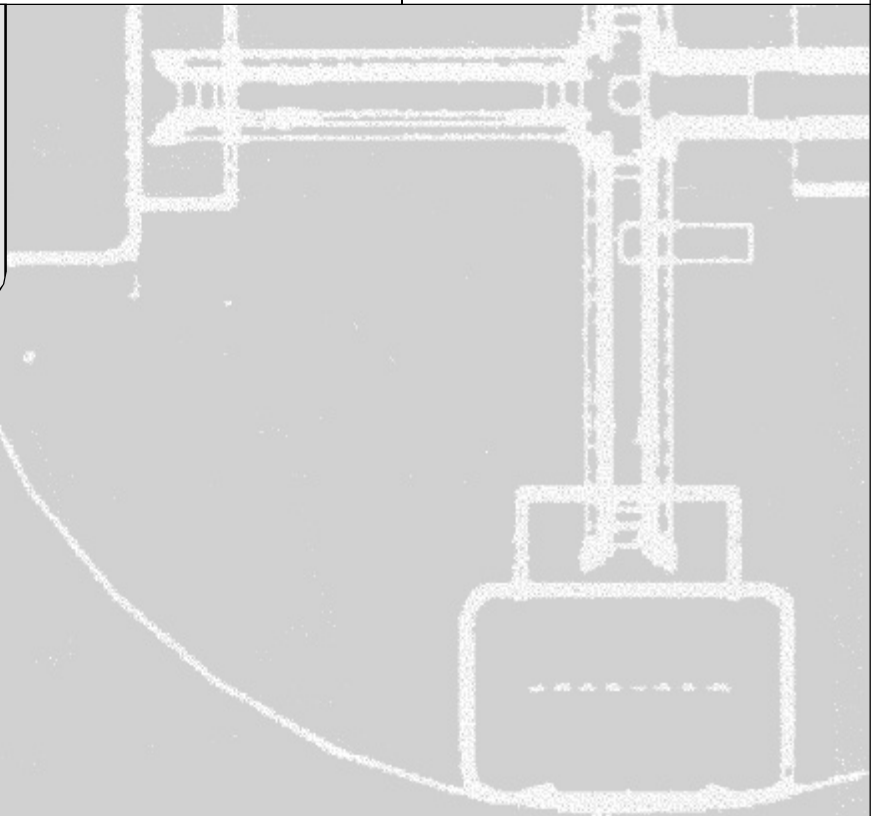

Important

Read, understand and obey these safety rules and operating instructions before operating this machine. Only trained and authorized personnel shall be permitted to operate this machine. This manual should be considered a permanent part of your machine and should remain with the machine at all times. If you have any questions, call Genie Industries.

Contents

	Page
Safety Rules	1
Legend	9
Controls	10
Pre-operation Inspection	12
Maintenance	14
Function Tests	16
Workplace Inspection	21
Operating Instructions	22
Transport and Lifting Instructions	27
Decals	30
Specifications	34

Contact us:

Internet: <http://www.genielift.com>
 e-mail: techpub@genieind.com

Copyright © 1997 by Genie Industries

First Edition: Seventeenth Printing, October 2002

Second Edition: First Printing, October 2003

Third Edition: Second Printing, July 2004

Fourth Edition: Second Printing, February 2006

"Genie" is a registered trademark of Genie Industries in the U.S.A. and many other countries. "GS" is a trademark of Genie Industries.

These machines comply with ANSI/SIA 92.6-1999.

 Printed on recycled paper

Printed in U.S.A.



Safety Rules



Danger

Failure to obey the instructions and safety rules in this manual will result in death or serious injury.

Do Not Operate Unless:

- You learn and practice the principles of safe machine operation contained in this operator's manual.

1 Avoid hazardous situations.

Know and understand the safety rules before going on to the next section.

2 Always perform a pre-operation inspection.

3 Always perform function tests prior to use.

4 Inspect the workplace.

5 Only use the machine as it was intended.

- You read, understand and obey the manufacturer's instructions and safety rules—safety and operator's manuals and machine decals.
- You read, understand and obey employer's safety rules and worksite regulations.
- You read, understand and obey all applicable governmental regulations.
- You are properly trained to safely operate the machine.

SAFETY RULES

Electrocution Hazards

This machine is not electrically insulated and will not provide protection from contact with or proximity to electrical current.

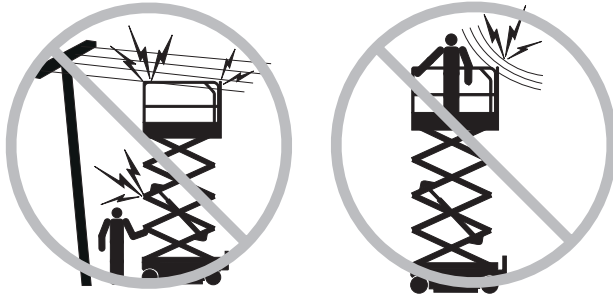

Maintain safe distances from electrical power lines and apparatus in accordance with applicable governmental regulations and the following chart.

Voltage Phase to Phase	Minimum Safe Approach Distance	
	Feet	Meters
0 to 300V	Avoid Contact	
300V to 50KV	10	3.05
50KV to 200KV	15	4.60
200KV to 350KV	20	6.10
350KV to 500KV	25	7.62
500KV to 750KV	35	10.67
750KV to 1000KV	45	13.72

Allow for platform movement, electrical line sway or sag and beware of strong or gusty winds.

Keep away from the machine if it contacts energized power lines. Personnel on the ground or in the platform must not touch or operate the machine until energized power lines are shut off.

Do not operate the machine during lightning or storms.

Do not use the machine as a ground for welding.

Tip-over Hazards

Occupants, equipment and materials must not exceed the maximum platform capacity or the maximum capacity of the platform extension.

Maximum capacity - GS-2032

Platform retracted	800 lbs	363 kg
Platform extended - Platform only	550 lbs	249 kg
Platform extended - Extension only	250 lbs	113 kg
Maximum occupants - ANSI and CSA	2	
Maximum occupants - Australia	1	
Outdoor use	1	
Indoor use only	2	



800 lbs / 363 kg



Extension only Platform only
250 lbs / 113 kg 550 lbs / 249 kg

SAFETY RULES

Maximum capacity - GS-2632

Platform retracted	500 lbs	227 kg
Platform extended - Platform only	250 lbs	113 kg
Platform extended - Extension only	250 lbs	113 kg
Maximum occupants - ANSI and CSA	2	
Maximum occupants - Australia Indoor use only	2	



500 lbs / 227 kg



Extension only Platform only
250 lbs / 113 kg 250 lbs / 113 kg

Do not raise the platform unless the machine is on a firm, level surface.



Do not depend on the tilt alarm as a level indicator. The tilt alarm sounds on the chassis only when the machine is on a slope.

If the tilt alarm sounds:
Lower the platform. Move the machine to a firm, level surface. If the tilt alarm sounds when the platform is raised, use extreme caution to lower the platform.

Do not alter or disable the limit switches.

Do not drive over 0.5 mph / 0.7 km/h with the platform raised.

Use extreme care and slow speeds while driving the machine in a stowed position across uneven terrain, debris, unstable or slippery surfaces and near holes and drop-offs.

Do not drive the machine on a slope that exceeds the slope and side slope rating of the machine. Slope rating applies to machines in the stowed position.

Maximum slope rating, stowed position 30% (17°)

Maximum side slope rating, stowed position 30% (17°)

Note: Slope rating is subject to ground conditions and adequate traction.

Do not use the platform controls to free a platform that is caught, snagged or otherwise prevented from normal motion by an adjacent structure. All personnel must be removed from the platform before attempting to free the platform using the ground controls.

Do not push off or pull toward any object outside of the platform.



Maximum allowable manual force

GS-2032

ANSI & CSA - 2 person	
120 lbs / 534 N	
Australia - Indoor use only - 2 person	90 lbs / 400 N
Australia - Outdoor use - 1 person	45 lbs / 200 N

GS-2632

ANSI & CSA - 2 person	100 lbs / 445 N
Australia - Indoor use only - 2 person	90 lbs / 400 N

SAFETY RULES

Do not alter or disable machine components that in any way affect safety and stability.

Do not modify or alter an aerial work platform without prior written permission from the manufacturer. Mounting attachments for holding tools or other materials onto the platform, toeboards or guard rail system can increase the weight in the platform and the surface area of the platform or the load.

Do not raise the platform when wind speeds may exceed 28 mph / 12.5 m/s. If wind speeds exceed 28 mph / 12.5 m/s when the platform is raised, lower the platform and do not continue to operate the machine.

Do not operate the machine in strong or gusty winds. Do not increase the surface area of the platform or the load. Increasing the area exposed to the wind will decrease machine stability.

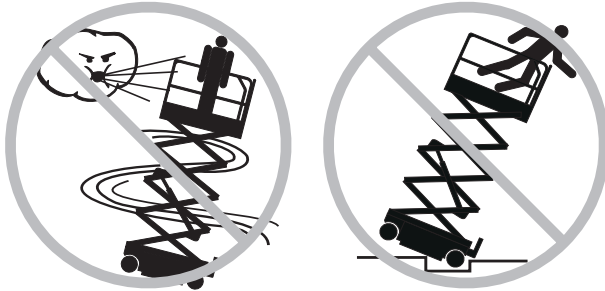

Do not drive the machine on or near uneven terrain, unstable surfaces or other hazardous conditions with the platform raised.

Do not replace items critical to machine stability with items of different weight or specification.

Do not place or attach fixed or overhanging loads to any part of this machine.

Do not transport tools and materials unless they are evenly distributed and can be safely handled by person(s) in the platform.



Do not place ladders or scaffolds in the platform or against any part of this machine.

Do not use the machine on a moving or mobile surface or vehicle.

Be sure all tires are in good condition, castle nuts are properly tightened and cotter pins are properly installed.

Do not use batteries that weigh less than the original equipment. Batteries are used as counterweight and are critical to machine stability. Each battery must weigh 65 pounds / 30 kg.

Do not use the machine as a crane.

Do not push the machine or other objects with the platform.

Do not contact adjacent structures with the platform.

Do not tie the platform to adjacent structures.

Do not place loads outside the platform perimeter.

Do not operate the machine with the chassis trays open.

SAFETY RULES

Fall Hazards

The guard rail system provides fall protection. If occupants of the platform are required to wear personal fall protection equipment (PFPE) due to job site or employer rules, PFPE equipment and its use shall be in accordance with the PFPE manufacturer's instructions and applicable governmental requirements.

Do not sit, stand or climb on the platform guard rails. Maintain a firm footing on the platform floor at all times.



Do not climb down from the platform when raised.

Keep the platform floor clear of debris.

Attach the platform entry chain or close the entry gate before operating.

Do not operate the machine unless the guard rails are properly installed and the entry is secured for operation.

Collision Hazards

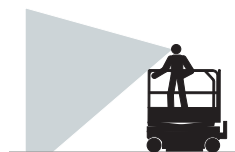

Be aware of limited sight distance and blind spots when driving or operating.

Be aware of the extended platform position when moving the machine.

The machine must be on a level surface or secured before releasing the brakes.

Operators must comply with employer, job site and governmental rules regarding use of personal protective equipment.

Check the work area for overhead obstructions or other possible hazards.

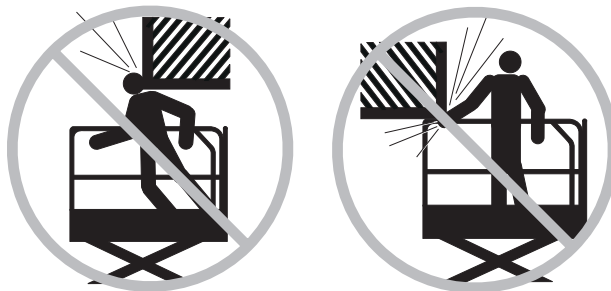

Be aware of crushing hazards when grasping the platform guard rail.

Observe and use the color-coded direction arrows on the platform controls and platform decal plate for drive and steer functions.

No stunt driving or horseplay while operating a machine.

SAFETY RULES

Do not lower the platform unless the area below is clear of personnel and obstructions.



Limit travel speed according to the condition of the ground surface, congestion, slope, location of personnel, and any other factors which may cause collision.

Do not operate a machine in the path of any crane or moving overhead machinery unless the controls of the crane have been locked out and/or precautions have been taken to prevent any potential collision.

Crushing Hazards

Keep hands and limbs out of scissors.

Do not work under the platform or in the scissor links without the safety arm in place.

Use common sense and planning when operating the machine with the controller from the ground. Maintain safe distances between the operator, the machine and fixed objects.

Component Damage Hazard

Do not use the machine as a ground for welding.

Explosion and Fire Hazard

Do not operate the machine in hazardous locations or locations where potentially flammable or explosive gases or particles may be present.

Damaged Machine Hazards

Do not use a damaged or malfunctioning machine.

Conduct a thorough pre-operation inspection of the machine and test all functions before each work shift. Immediately tag and remove from service a damaged or malfunctioning machine.

Be sure all maintenance has been performed as specified in this manual and the appropriate service manual.

Be sure all decals are in place and legible.

Be sure the operator's, safety, and responsibilities manuals are complete, legible and in the storage container located on the platform.

SAFETY RULES

Bodily Injury Hazard

Do not operate the machine with a hydraulic oil or air leak. An air leak or hydraulic leak can penetrate and/or burn skin.

Improper contact with components under any cover will cause serious injury. Only trained maintenance personnel should access compartments. Access by the operator is only advised when performing a pre-operation inspection. All compartments must remain closed and secured during operation.

Decal Legend

Genie product decals use symbols, color coding and signal words to identify the following:



Safety alert symbol—used to alert personnel to potential personal injury hazards. Obey all safety messages that follow this symbol to avoid possible injury or death.

▲ DANGER



Red—used to indicate the presence of an imminently hazardous situation which, if not avoided, will result in death or serious injury.

▲ WARNING



Orange—used to indicate the presence of a potentially hazardous situation which, if not avoided, could result in death or serious injury.

▲ CAUTION



Yellow with safety alert symbol—used to indicate the presence of a potentially hazardous situation which, if not avoided, may cause minor or moderate injury.

CAUTION

Yellow without safety alert symbol—used to indicate the presence of a potentially hazardous situation which, if not avoided, may result in property damage.

NOTICE

Green—used to indicate operation or maintenance information.

SAFETY RULES

Battery Safety**Burn Hazards**

Batteries contain acid. Always wear protective clothing and eye wear when working with batteries.



Avoid spilling or contacting battery acid. Neutralize battery acid spills with baking soda and water.

Do not expose the batteries or the charger to water or rain during charging.

Explosion Hazards

Keep sparks, flames and lighted tobacco away from batteries. Batteries emit an explosive gas.

The battery tray should remain open during the entire charging cycle.

Do not contact the battery terminals or the cable clamps with tools that may cause sparks.

Component Damage Hazard

Do not use any battery charger greater than 24V to charge the batteries.

Electrocution Hazards

Connect the battery charger to a grounded, AC 3-wire electrical outlet only.

Inspect daily for damaged cord, cables and wires. Replace damaged items before operating.

Avoid electrical shock from contact with battery terminals. Remove all rings, watches and other jewelry.

Tip-over Hazard

Do not use batteries that weigh less than the original equipment. Batteries are used as counterweight and are critical to machine stability. Each battery must weigh 65 pounds / 30 kg.

Lifting Hazard

Use the appropriate number of people and proper lifting techniques when lifting batteries.

Legend

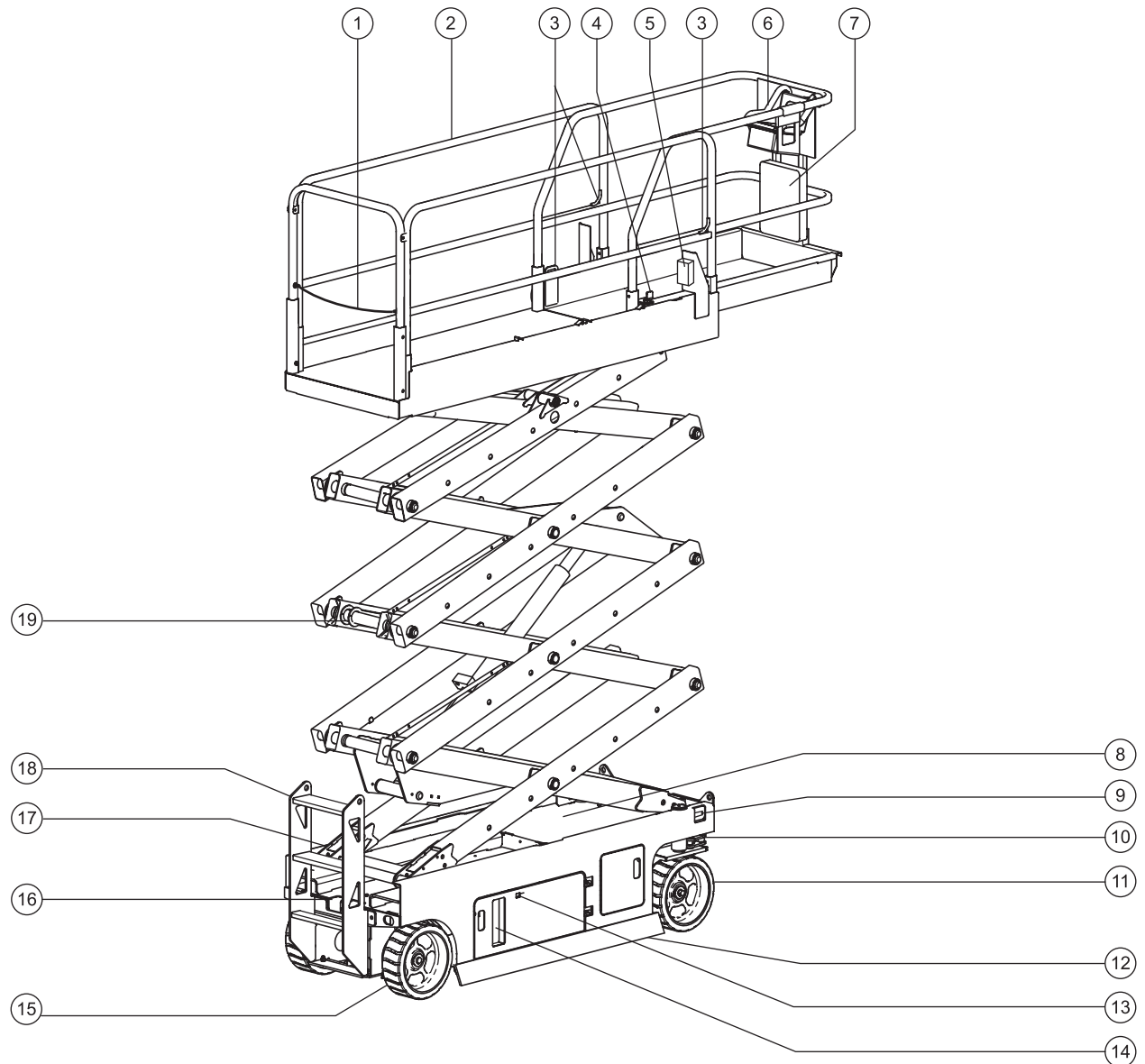

- | | | |
|--------------------------------------|----------------------------|--|
| 1 Platform entry chain or entry gate | 7 Manual storage container | 15 Non-steer tire |
| 2 Platform guard rails | 8 Tilt alarm (under cover) | 16 Brake release pump knob and release knob |
| 3 Lanyard anchorage point | 9 Auxiliary lowering lever | 17 Battery charger (on opposite side of machine) |
| 4 Platform extension release pedal | 10 Transport tie-down | 18 Entry ladder/transport tie-down |
| 5 GFCI outlet | 11 Steer tire | 19 Safety arm |
| 6 Platform controls | 12 Pothole guard | |
| | 13 LED diagnostic readout | |
| | 14 Ground controls | |



Controls

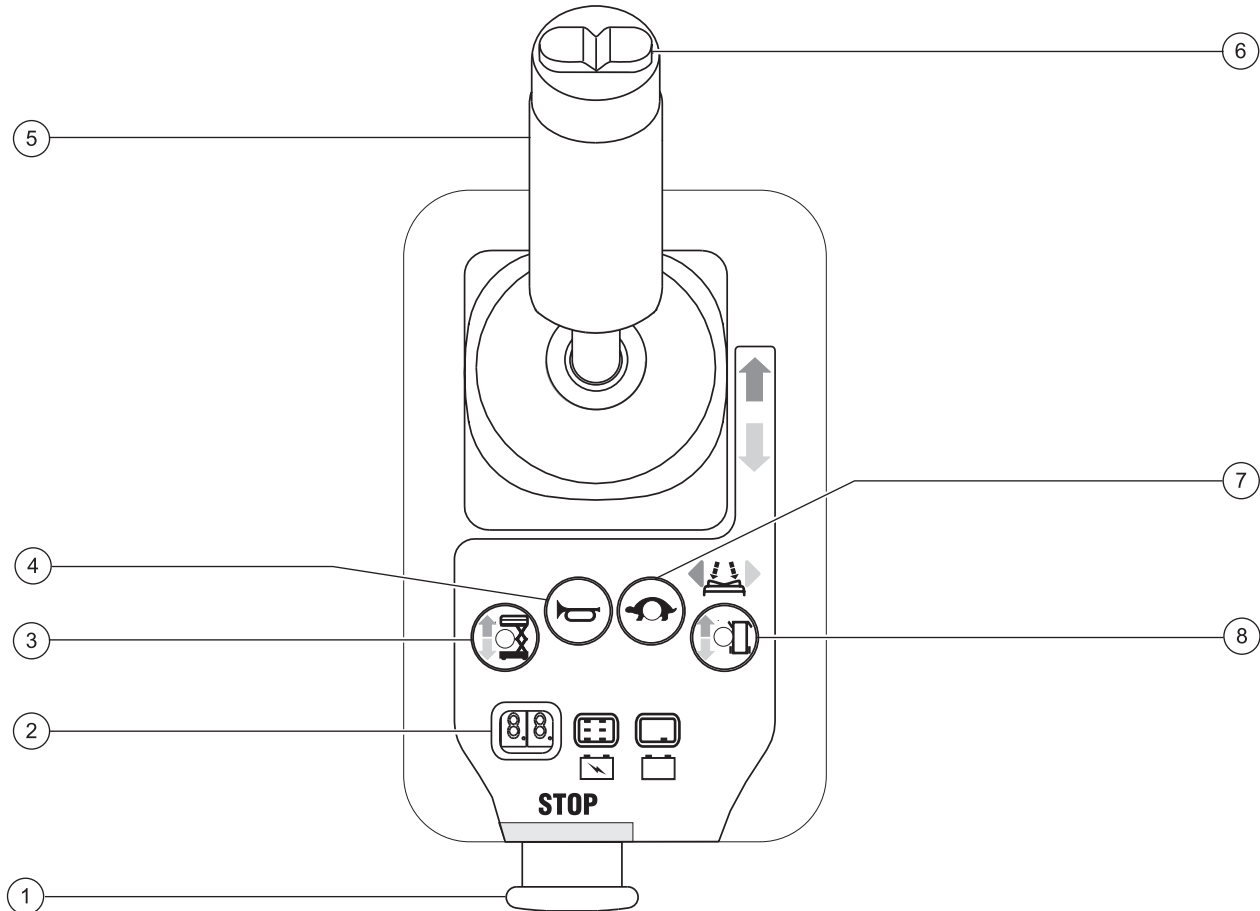

Platform Controls

- | | |
|--|--|
| <ul style="list-style-type: none"> 1 Red Emergency Stop button 2 LED diagnostic readout / Battery charge indicator 3 Lift function select button 4 Horn button | <ul style="list-style-type: none"> 5 Proportional control handle and function enable switch for lift and drive functions 6 Thumb rocker switch for steer functions 7 Drive speed button 8 Drive function select button |
|--|--|

CONTROLS

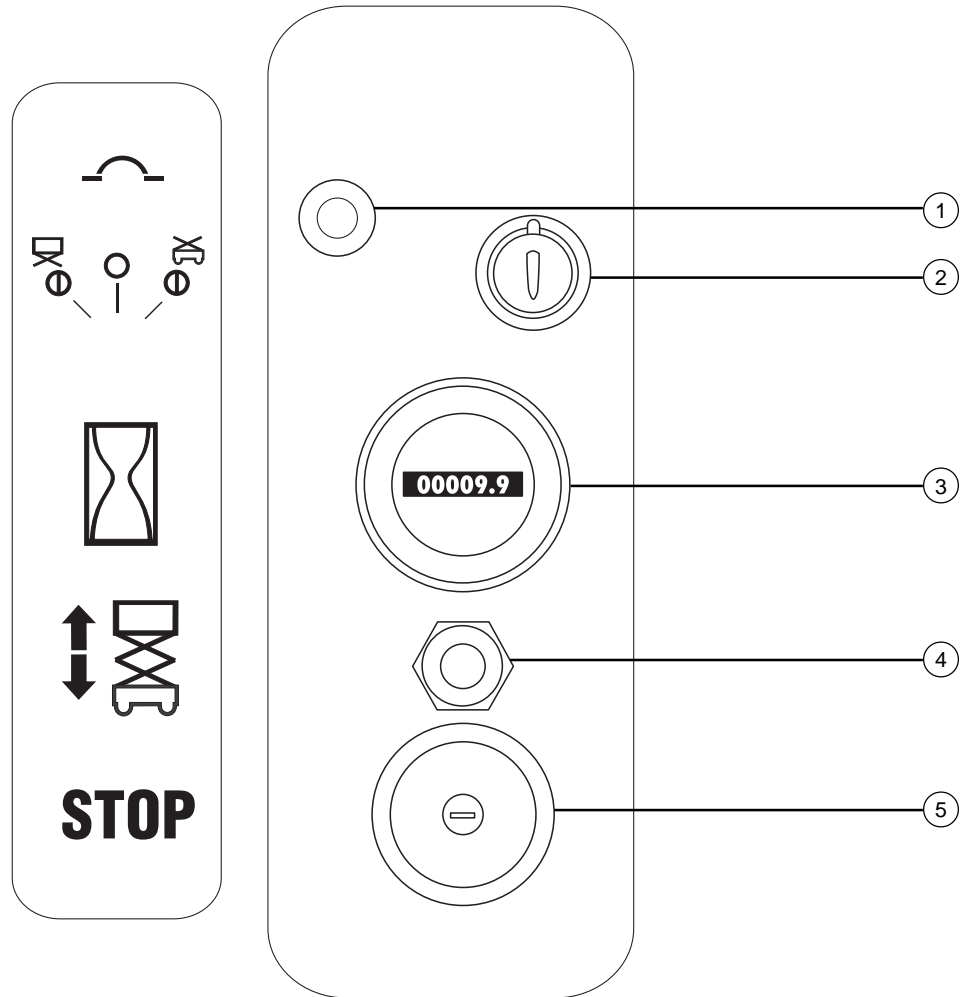

Ground Control Panel

- 1 7 amp breaker for electrical circuits
- 2 Key switch for platform/off/ground selection
- 3 Hour meter
- 4 Platform up/down toggle switch
- 5 Red Emergency Stop button

Pre-operation Inspection



Do Not Operate Unless:

- You learn and practice the principles of safe machine operation contained in this operator's manual.

1 Avoid hazardous situations.

2 Always perform a pre-operation inspection.

Know and understand the pre-operation inspection before going on to the next section.

3 Always perform function tests prior to use.

4 Inspect the workplace.

5 Only use the machine as it was intended.

Fundamentals

It is the responsibility of the operator to perform a pre-operation inspection and routine maintenance.

The pre-operation inspection is a visual inspection performed by the operator prior to each work shift. The inspection is designed to discover if anything is apparently wrong with a machine before the operator performs the function tests.

The pre-operation inspection also serves to determine if routine maintenance procedures are required. Only routine maintenance items specified in this manual may be performed by the operator.

Refer to the list on the next page and check each of the items.

If damage or any unauthorized variation from factory delivered condition is discovered, the machine must be tagged and removed from service.

Repairs to the machine may only be made by a qualified service technician, according to the manufacturer's specifications. After repairs are completed, the operator must perform a pre-operation inspection again before going on to the function tests.

Scheduled maintenance inspections shall be performed by qualified service technicians, according to the manufacturer's specifications and the requirements listed in the responsibilities manual.

Pre-operation Inspection

- Be sure that the operator's, safety and responsibilities manuals are complete, legible and in the storage container located on the platform.
- Be sure that all decals are legible and in place. See Decals section.
- Check for hydraulic oil leaks and proper oil level. Add oil if needed. See Maintenance section.
- Check for battery fluid leaks and proper fluid level. Add distilled water if needed. See Maintenance section.

Check the following components or areas for damage, improperly installed or missing parts and unauthorized modifications:

- Electrical components, wiring and electrical cables
- Hydraulic power unit, tank, hoses, fittings, cylinders and manifolds
- Battery pack and connections
- Drive motors
- Wear pads
- Tires and wheels
- Ground strap
- Limit switches, alarms and horn
- Nuts, bolts and other fasteners
- Platform entry chain or gate
- Beacon and alarms (if equipped)
- Brake release components
- Safety arm

- Pothole guards
- Platform extension
- Scissor pins and retaining fasteners
- Platform control joystick

Check entire machine for:

- Cracks in welds or structural components
- Dents or damage to machine
- Excessive rust, corrosion or oxidation
- Be sure that all structural and other critical components are present and all associated fasteners and pins are in place and properly tightened.
- Be sure side rails are installed and bolts are fastened
- Be sure that the chassis trays are closed and latched and the batteries are properly connected.

Note: If the platform must be raised to inspect the machine, make sure the safety arm is in place. See Operating Instructions section.

Maintenance



Observe and Obey:

- ☑ Only routine maintenance items specified in this manual shall be performed by the operator.
- ☑ Scheduled maintenance inspections shall be completed by qualified service technicians, according to the manufacturer's specifications and the requirements specified in the responsibilities manual.

Maintenance Symbols Legend

NOTICE The following symbols have been used in this manual to help communicate the intent of the instructions. When one or more of the symbols appear at the beginning of a maintenance procedure, it conveys the meaning below.



Indicates that tools will be required to perform this procedure.



Indicates that new parts will be required to perform this procedure.

Check the Hydraulic Oil Level



Maintaining the hydraulic oil at the proper levels is essential to machine operation. Improper hydraulic oil levels can damage hydraulic components. Daily checks allow the inspector to identify changes in oil level that might indicate the presence of hydraulic system problems.

NOTICE Perform this procedure with the platform in the stowed position.

- 1 Visually inspect the oil level in the hydraulic tank.
- ⦿ Result: The hydraulic oil level should be at the FULL mark on the tank.
- 2 Add oil if necessary. Do not overfill.

Hydraulic oil specifications

Hydraulic oil type	Chevron Rykon Premium MV equivalent
--------------------	--

MAINTENANCE

Check the Batteries



Proper battery condition is essential to good performance and operational safety. Improper fluid levels or damaged cables and connections can result in component damage and hazardous conditions.

NOTICE This procedure does not need to be performed on machines with sealed or maintenance-free batteries.

⚠ WARNING Electrocuting hazard. Contact with hot or live circuits may result in death or serious injury. Remove all rings, watches and other jewelry.

⚠ WARNING Bodily injury hazard. Batteries contain acid. Avoid spilling or contacting battery acid. Neutralize battery acid spills with baking soda and water.

NOTICE Perform this test after fully charging the batteries.

- 1 Put on protective clothing and eye wear.
- 2 Be sure that the battery cable connections are tight and free of corrosion.
- 3 Be sure that the battery retaining fasteners are in place and secure.
- 4 Remove the battery vent caps.
- 5 Check the battery acid level of each battery. If needed, replenish with distilled water to the bottom of the battery fill tube. Do not overfill.
- 6 Install the vent caps.

Scheduled Maintenance

Maintenance performed quarterly, annually and every two years must be completed by a person trained and qualified to perform maintenance on this machine according to the procedures found in the service manual for this machine.

Machines that have been out of service for more than three months must receive the quarterly inspection before they are put back into service.

Function Tests



Do Not Operate Unless:

- You learn and practice the principles of safe machine operation contained in this operator's manual.
 - 1 Avoid hazardous situations.
 - 2 Always perform a pre-operation inspection.
 - 3 Always perform function tests prior to use.**

Know and understand the function tests before going on to the next section.

- 4 Inspect the workplace.
- 5 Only use the machine as it was intended.

Fundamentals

The function tests are designed to discover any malfunctions before the machine is put into service. The operator must follow the step-by-step instructions to test all machine functions.

A malfunctioning machine must never be used. If malfunctions are discovered, the machine must be tagged and removed from service. Repairs to the machine may only be made by a qualified service technician, according to the manufacturer's specifications.

After repairs are completed, the operator must perform a pre-operation inspection and function tests again before putting the machine into service.

FUNCTION TESTS

- 1 Select a test area that is firm, level and free of obstruction.
- 2 Be sure the battery pack is connected.

At the Ground Controls

- 3 Pull out the platform and ground red Emergency Stop buttons to the on position.
- 4 Turn the key switch to ground control.
- 5 Observe the diagnostic LED readout.

- ⦿ Result: The LED should look like the picture at right.



Test Emergency Stop

- 6 Push in the ground red Emergency Stop button to the off position.
- ⦿ Result: No functions should operate.
- 7 Pull out the red Emergency Stop button to the on position.

Test the Up/Down Functions

The audible warnings on this machine and the standard horn all come from the same central alarm. The horn is a constant tone. The descent alarm sounds at 60 beeps per minute. The alarm that goes off when the pothole guards have not deployed sounds at 300 beeps per minute. The alarm that goes off when the machine is not level sounds at 600 beeps per minute. An optional automotive-style horn is also available.

- 8 Activate the up function.
- ⦿ Result: The platform should raise.
- 9 Activate the down function.
- ⦿ Result: The platform should lower. The descent alarm should sound while the platform is lowering.

Test Auxiliary Lowering

- 10 Activate the up function and raise the platform approximately 2 feet / 60 cm.
- 11 Pull the auxiliary lowering knob.
- ⦿ Result: The platform should lower. The descent alarm will not sound.
- 12 Turn the key switch to platform control.

At the Platform Controls

Test Emergency Stop

- 13 Push in the platform red Emergency Stop button to the off position.
- ⦿ Result: No functions should operate.

Test the Horn

- 14 Pull the red Emergency Stop button out to the on position.
- 15 Push the horn button.
- ⦿ Result: The horn should sound.

FUNCTION TESTS

Test the Function Enable Switch

- 16 Do not hold the function enable switch on the control handle.
- 17 Slowly move the control handle in the direction indicated by the blue arrow, then in the direction indicated by the yellow arrow.

⦿ Result: No functions should operate.

Test the Up/Down Functions

- 18 Press the lift function select button.
- 19 Press and hold the function enable switch on the control handle.



- 20 Slowly move the control handle in the direction indicated by the blue arrow.

⦿ Result: The platform should raise. The pothole guards should deploy.

- 21 Release the control handle.

⦿ Result: The platform should stop raising.

- 22 Press and hold the function enable switch. Slowly move the control handle in the direction indicated by the yellow arrow.

⦿ Result: The platform should lower. The descent alarm should sound while the platform is lowering.

Test the Steering

Note: When performing the steer and drive function tests, stand in the platform facing the steer end of the machine.

- 23 Press the drive function select switch.



- 24 Press and hold the function enable switch on the control handle.

- 25 Depress the thumb rocker switch on top of the control handle in the direction identified by the blue triangle on the control panel.

⦿ Result: The steer wheels should turn in the direction that the blue triangle points on the control panel.

- 26 Depress the thumb rocker switch in the direction identified by the yellow triangle on the control panel.

⦿ Result: The steer wheels should turn in the direction that the yellow triangle points on the control panel.

FUNCTION TESTS

Test Drive and Braking

- 27 Press and hold the function enable switch on the control handle.
- 28 Slowly move the control handle in the direction indicated by the blue arrow on the control panel until the machine begins to move, then return the handle to the center position.
- ⦿ Result: The machine should move in the direction that the blue arrow points on the control panel, then come to an abrupt stop.
- 29 Slowly move the control handle in the direction indicated by the yellow arrow on the control panel until the machine begins to move, then return the handle to the center position.
- ⦿ Result: The machine should move in the direction that the yellow arrow points on the control panel, then come to an abrupt stop.

Note: The brakes must be able to hold the machine on any slope it is able to climb.

Test the Tilt Sensor Operation

Note: Perform this test from the ground with the platform controller. Do not stand in the platform.

- 30 Fully lower the platform.
- 31 Place a 2x4 or similar piece of wood under both wheels on one side and drive the machine up onto them.
- 32 Raise the platform approximately 7 feet / 2.1 m from the ground.
- ⦿ Result: The platform should stop and the tilt alarm will sound at 600 beeps per minute.
- 33 Move the drive control handle in the direction indicated by the blue arrow, then move the drive control handle in the direction indicated by the yellow arrow.
- ⦿ Result: The drive function should not work in either direction.
- 34 Lower the platform and remove both pieces of wood.

Test Limited Drive Speed

- 35 Press the lift function select button.
- 36 Press and hold the function enable switch on the control handle. Raise the platform approximately 4 feet / 1.2 m from the ground.
 - ⦿ Result: The pothole guards should deploy.
- 37 Press the drive function select switch.
- 38 Press and hold the function enable switch on the control handle. Slowly move the control handle to the full drive position.
 - ⦿ Result: The maximum achievable drive speed with the platform raised should not exceed 0.75 feet / 23 cm per second.

If the drive speed with the platform raised exceeds 0.75 feet / 23 cm per second, immediately tag and remove the machine from service.

Test the Pothole Guards

Note: The pothole guards should automatically deploy when the platform is raised. The pothole guards activate two limit switches which control the machine drive speed. If the pothole guards do not deploy and the platform is raised above 6 feet / 1.8 m, an alarm sounds and the machine will not drive.

- 39 Raise the platform.
 - ⦿ Result: When the platform is raised 4 feet / 1.2 m from the ground, the pothole guards should deploy.
- 40 Press on the pothole guards on one side, and then the other.
 - ⦿ Result: The pothole guards should not move.
- 41 Lower the platform.
 - ⦿ Result: The pothole guards should return to the stowed position.
- 42 Place a 2x4 or similar piece of wood under a pothole guard. Raise the platform.
 - ⦿ Result: Before the platform is raised 7 feet / 2.1 m from the ground, an alarm should sound and the drive function should not work.
- 43 Lower the platform and remove the 2x4.

Workplace Inspection



Do Not Operate Unless:

- You learn and practice the principles of safe machine operation contained in this operator's manual.
 - 1 Avoid hazardous situations.
 - 2 Always perform a pre-operation inspection.
 - 3 Always perform function tests prior to use.
 - 4 Inspect the workplace.**
- Know and understand the workplace inspection before going on to the next section.**
- 5 Only use the machine as it was intended.

Fundamentals

The workplace inspection helps the operator determine if the workplace is suitable for safe machine operation. It should be performed by the operator prior to moving the machine to the workplace.

It is the operator's responsibility to read and remember the workplace hazards, then watch for and avoid them while moving, setting up and operating the machine.

Workplace Inspection

Be aware of and avoid the following hazardous situations:

- drop-offs or holes
- bumps, floor obstructions or debris
- sloped surfaces
- unstable or slippery surfaces
- overhead obstructions and high voltage conductors
- hazardous locations
- inadequate surface support to withstand all load forces imposed by the machine
- wind and weather conditions
- the presence of unauthorized personnel
- other possible unsafe conditions

Operating Instructions



Do Not Operate Unless:

- You learn and practice the principles of safe machine operation contained in this operator's manual.
 - 1 Avoid hazardous situations.
 - 2 Always perform a pre-operation inspection.
 - 3 Always perform function tests prior to use.
 - 4 Inspect the workplace.
 - 5 Only use the machine as it was intended.**

Fundamentals

The Operating Instructions section provides instructions for each aspect of machine operation. It is the operator's responsibility to follow all the safety rules and instructions in the operator's, safety and responsibilities manuals.

Using the machine for anything other than lifting personnel, along with their tools and materials, to an aerial work site is unsafe and dangerous.

Only trained and authorized personnel should be permitted to operate a machine. If more than one operator is expected to use a machine at different times in the same work shift, they must all be qualified operators and are all expected to follow all safety rules and instructions in the operator's, safety and responsibilities manuals. That means every new operator should perform a pre-operation inspection, function tests, and a workplace inspection before using the machine.

OPERATING INSTRUCTIONS

Emergency Stop

Push in the red Emergency Stop button to the off position at the ground controls or the platform controls to stop all functions.

Repair any function that operates when either red Emergency Stop button is pushed in.

Auxiliary Lowering

- 1 Pull the auxiliary lowering knob.

Operation From Ground

- 1 Turn the key switch to ground control.
- 2 Pull out both ground and platform red Emergency Stop buttons to the on position.
- 3 Be sure the battery pack is connected before operating the machine.

To Position Platform

- 1 Move the up/down toggle switch according to the markings on the control panel.

Drive and steer functions are not available from the ground controls.

Operation From Platform

- 1 Turn the key switch to platform control.
- 2 Pull out the ground and platform red Emergency Stop buttons to the on position.
- 3 Be sure the battery pack is connected before operating the machine.

To Position Platform

- 1 Press the lift function select button.
- 2 Press and hold the function enable switch on the control handle.
- 3 Move the control handle according to the markings on the control panel.



To Steer

- 1 Press the drive function select button.
- 2 Press and hold the function enable switch on the control handle.
- 3 Turn the steer wheels with the thumb rocker switch located on the top of the control handle.

To Drive

- 1 Press the drive function select button.
- 2 Press and hold the function enable switch on the control handle.
- 3 Increase speed: Slowly move the control handle off center.
Decrease speed: Slowly move the control handle toward center.
Stop: Return the control handle to center or release the function enable switch.



Use the color-coded direction arrows on the platform controls and on the platform to identify the direction the machine will travel.

Machine travel speed is restricted when the platform is raised.

Battery condition will affect machine performance. Machine drive speed and function speed will drop when battery level indicator is flashing.

OPERATING INSTRUCTIONS

To reduce drive speed

The drive controls can operate in two different drive speed modes. When the drive speed button light is on, slow drive speed mode is active. When the button light is off, fast drive speed mode is active.



Press the drive speed button to select the desired drive speed.

Driving on a slope

Determine the slope and side slope ratings for the machine and determine the slope grade.



Maximum slope rating, stowed position: 30% (17°)



Maximum side slope rating, stowed position: 30% (17°)

Note: Slope rating is subject to ground conditions and adequate traction.

Press the drive speed button to the fast drive speed mode.

To determine the slope grade:

Measure the slope with a digital inclinometer OR use the following procedure.

You will need:

- carpenter's level
- straight piece of wood, at least 3 feet / 1 m long
- tape measure

Lay the piece of wood on the slope.

At downhill end, lay the level on the top edge of the piece of wood and lift the end until the piece of wood is level.

While holding the piece of wood level, measure the distance from the bottom of the piece of wood to the ground.

Divide the tape measure distance (rise) by the length of the piece of wood (run) and multiply by 100.

Example:

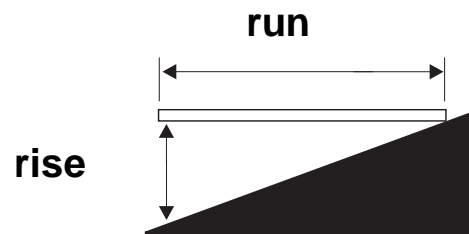

$$\text{Run} = 12 \text{ ft (144 in) / 3.6 m}$$

$$\text{Rise} = 12 \text{ in / 0.3 m}$$

$$12 \text{ in} \div 144 \text{ in} = 0.083 \times 100 = 8.3\%$$

$$0.3 \text{ m} \div 3.6 \text{ m} = 0.083 \times 100 = 8.3\%$$

OPERATING INSTRUCTIONS

Error indicator readout

If the LED diagnostic readout displays an error code, such as LL, push in and pull out the red Emergency Stop button to reset the system.

To Extend and Retract Platform

- 1 Step on the platform extension release pedal on the platform toeboard.
- 2 Grasp the platform guard rails and carefully push to extend the platform to the mid-position stop.
- 3 Step on the release pedal again and push to fully extend the platform.

Do not stand on the platform extension while trying to extend it.

- 4 Step on the platform extension release pedal and pull to retract the platform to the mid-position stop. Step again to fully retract the platform.

Operation From Ground with Controller

Maintain safe distances between the operator, machine and fixed objects.

Be aware of the direction the machine will travel when using the controller.

Battery Level Indicator

Use the LED diagnostic readout to determine the battery level.

Fall Protection

Personal fall protection equipment (PFPE) is not required when operating this machine. If PFPE is required by job site or employer rules, the following shall apply:

All PFPE must comply with applicable governmental regulations and must be inspected and used in accordance with the manufacturer's instructions.

After Each Use

- 1 Select a safe parking location—firm level surface, clear of obstruction and traffic.
- 2 Lower the platform.
- 3 Turn the key switch to the off position and remove the key to secure from unauthorized use.
- 4 Chock the wheels.
- 5 Charge the batteries.

How to use the Safety Arm

- 1 Raise the platform approximately 2.4 m from the ground.
- 2 Rotate the safety arm away from the machine and let it hang down.
- 3 Lower the platform until the safety arm rests securely on the link. Keep clear of the safety arm when lowering the platform.

OPERATING INSTRUCTIONS



Battery and Charger Instructions

Observe and Obey:

- Do not use an external charger or booster battery.
Charge the battery in a well-ventilated area.
- Use proper AC input voltage for charging as indicated on the charger.
- Use only Genie authorized battery and charger.

To Charge Battery

- 1 Be sure the batteries are connected before charging the batteries.
- 2 Open the battery compartment. The compartment should remain open for the entire charging cycle.

Maintenance-free batteries

- 3 Connect the battery charger to a grounded AC circuit.
- 4 The charger will indicate when the battery is fully charged.

Standard Batteries

- 3 Remove the battery vent caps and check the battery acid level. If necessary, add only enough distilled water to cover the plates. Do not overfill prior to the charge cycle.
- 4 Replace the battery vent caps.
- 5 Connect the battery charger to a grounded AC circuit.
- 6 The charger will indicate when the battery is fully charged.
- 7 Check the battery acid level when the charging cycle is complete. Replenish with distilled water to the bottom of the fill tube. Do not overfill.

Dry Battery Filling and Charging Instructions

- 1 Remove the battery vent caps and permanently remove the plastic seal from the battery vent openings.
- 2 Fill each cell with battery acid (electrolyte) until the level is sufficient to cover the plates.

Do not fill to the maximum level until the battery charge cycle is complete. Overfilling can cause the battery acid to overflow during charging. Neutralize battery acid spills with baking soda and water.

- 3 Install the battery vent caps.
- 4 Charge the battery.
- 5 Check the battery acid level when the charging cycle is complete. Replenish with distilled water to the bottom of the fill tube. Do not overfill.

Transport and Lifting Instructions



Observe and Obey:

Common sense and planning must be applied to control the movement of the machine when lifting it with a crane or forklift.

- ☑ The transport vehicle must be parked on a level surface.
- ☑ The transport vehicle must be secured to prevent rolling while the machine is being loaded.
- ☑ Be sure the vehicle capacity, loading surfaces and chains or straps are sufficient to withstand the machine weight. See the serial plate for the machine weight.
- ☑ The machine must be on a level surface or secured before releasing the brakes.
- ☑ Do not allow the rails to fall when the snap pins are removed. Maintain a firm grasp on the rails when the rails are lowered.
- ☑ Do not drive the machine on a slope that exceeds the slope or side slope rating. See Driving on a Slope in the Operating Instructions section.
- ☑ If the slope of the transport vehicle bed exceeds the maximum slope rating, the machine must be loaded and unloaded using a winch as described.

Brake Release Operation



- 1 Chock the wheels to prevent the machine from rolling.
- 2 Be sure the winch line is properly secured to the drive chassis tie points and the path is clear of all obstructions.
- 3 Push in the black brake release knob to open the brake valve.
- 4 Pump the red brake release pump knob.

After the machine is loaded:

- 1 Chock the wheels to prevent the machine from rolling.
- 2 Press the drive function select button. Press and hold the function enable switch on the control handle. Move the control handle off center to reset the brakes.

Towing the Genie GS-2032 and the GS-2632 is not recommended. If the machine must be towed, do not exceed 2 mph / 3.2 km/h.

TRANSPORT AND LIFTING INSTRUCTIONS



Observe and Obey:

- Only qualified riggers should rig and lift the machine.
- Be sure the crane capacity, loading surfaces and straps or lines are sufficient to withstand the machine weight. See the serial plate for the machine weight.

Lifting Instructions

Fully lower the platform. Be sure the extension deck, controls and component trays are secure. Remove all loose items on the machine.

Determine the center of gravity of your machine using the table and the picture on this page.

Attach the rigging only to the designated lifting points on the machine. There are two 1 inch / 2.5 cm holes on the front of the machine and two holes in the ladder for lifting.

Adjust the rigging to prevent damage to the machine and to keep the machine level.

Center of gravity	X Axis	Y Axis
ANSI and CSA models		
GS-2032	35.6 in 90.5 cm	22.2 in 56.5 cm
GS-2632	31.7 in 80.6 cm	22.7 in 57.6 cm
Australia models		
GS-2032	31.9 in 80.9 cm	21.2 in 53.9 cm
GS-2632	32.4 in 82.2 cm	23.3 in 59.3 cm

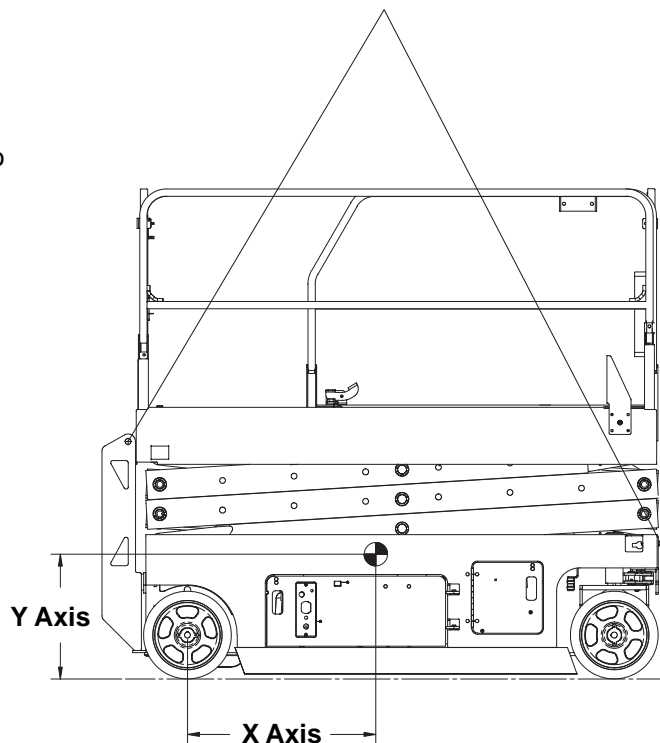

TRANSPORT AND LIFTING INSTRUCTIONS

Securing to Truck or Trailer for Transit

Always use the extension deck lock when the machine is transported.

Turn the key switch to the off position and remove the key before transporting.

Inspect the entire machine for loose or unsecured items.

Use chains or straps of ample load capacity.

Use a minimum of 2 chains or straps.

Adjust the rigging to prevent damage to the chains.

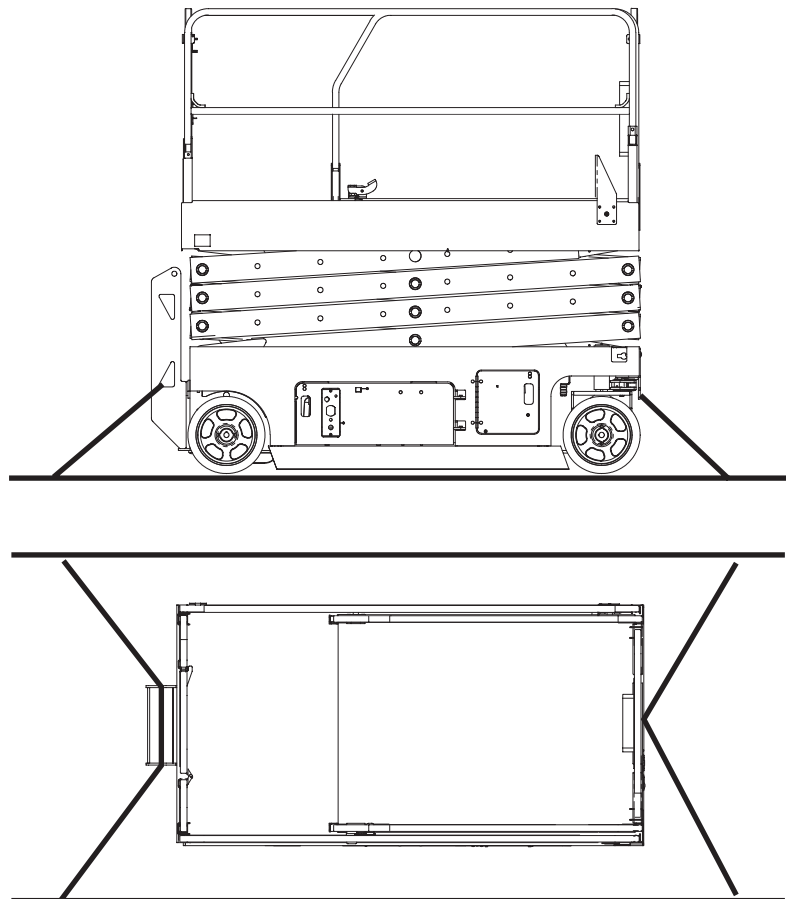

Decals

Inspection for Decals with Words

Determine whether the decals on your machine have words or symbols. Use the appropriate inspection to verify that all decals are legible and in place.

Part No.	Description	Quantity
28164	Notice - Hazardous Materials	1
28171	Label - No Smoking	1
28174	Label - Power to Platform, 230V	2
28175	Caution - Compartment Access	1
28176	Notice - Missing Manuals	1
28235	Label - Power to Platform, 115V	2
28236	Warning - Failure To Read . . .	1
31060	Danger - Do Not Alter Limit Switch	1
31508	Notice - Power to Battery Charger	1
40434	Label - Lanyard Anchorage	5
43089	Notice - Operating Instructions, Ground	1
43617	Danger - Tip-over (batteries)	1
43618	Label - Directional Arrows	2
43619	Label - Safety Arm	1
43658	Label - Power to Charger, 230V	1
43696	Danger - Electrocution Hazard	2
44255	Danger - Crushing Hazard	4
44736	Danger - Tilt Alarm	1
44737	Danger - Tip-over, Trays Open	2
44753	Label - LED Diagnostic Readout	1
44980	Label - Power to Charger, 115V	1
44981	Label - Air to Platform, 110 PSI	2
46262	Danger - Battery/Charger Safety	1
46287	Notice - Tire Specification	4
52475	Label - Transport Tie-down	5
65052	Label - ECU Fault Codes	1
62055	Cosmetic - Genie GS-2032	2

Part No.	Description	Quantity
72143	Label - Emergency Stop	1
72853	Danger - Improper Use Hazard	1
72970	Notice - Battery Charger Operating Instructions	1
72973	Cosmetic - Genie GS-2632	2
82307	Notice - Side Force, GS-2632, Australia	1
82366	Label - Chevron Rykon	1
82447	Label - Auxiliary Lowering	1
82557	Label - Platform Controls Location	1
82558	Warning - Skin Injection Hazard	1
82559	Notice - Annual Inspection	1
82561	Danger - Crushing Hazard	2
82563	Notice - Max Cap 500 lbs / 227 kg, GS-2632	1
82567	Ground Control Panel	1
82657	Notice - Battery Connection Diagram	1
82693	Notice - Max Cap 800 lbs / 363 kg, GS-2032	1
82694	Notice - Side Force, GS-2032, ANSI & CSA	1
82695	Notice - Side Force, GS-2632, ANSI & CSA	1
97692	Label - Wheel Load, GS-2032	4
97693	Label - Wheel Load, GS-2632	4
97694	Notice - Side Force, GS-2032, Australia	1
97712	Danger/Notice - Brake Release Safety & Operating Instructions	1
97772	Platform Control Panel	1
1000042	Danger - General Safety Rules	1
1000062	Notice - Operating Instructions, Platform	1

DECALS

Decal Part Numbers			
each model requires 1 Capacity decal and 1 Side Force decal			
		GS-2032	GS-2632
ANSI	Capacity	82693	82563
	Side Force	82694	82695
CSA	Capacity	82693	82563
	Side Force	82694	82695
Australia	Capacity	82693	82563
	Side Force	97694	82307

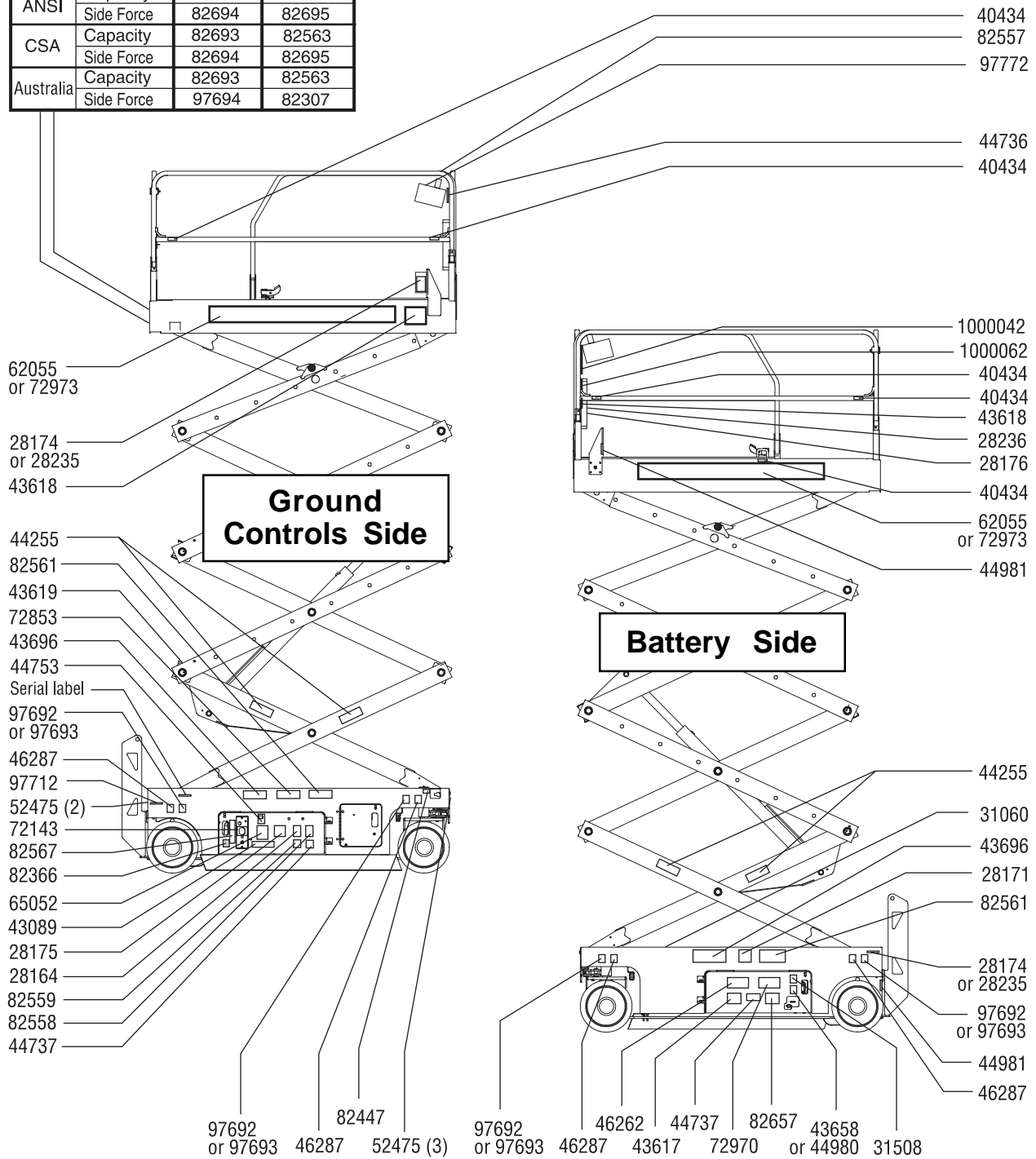

DECALS

Inspection for Decals with Symbols

Determine whether the decals on your machine have words or symbols. Use the appropriate inspection to verify that all decals are legible and in place.

Part No.	Description	Quantity
28174	Label - Power to Platform, 230V	2
28235	Label - Power to Platform, 115V	2
40434	Label - Lanyard Anchorage	5
43618	Label - Directional Arrows	2
43658	Label - Power to Charger, 230V	1
44980	Label - Power to Charger, 115V	1
44981	Label - Air to Platform, 110 PSI	2
52475	Label - Transport Tie-down	5
62055	Cosmetic - Genie GS-2032	2
72143	Label - Emergency Stop	1
72973	Cosmetic - Genie GS-2632	2
82472	Warning - Crushing Hazard	1
82474	Warning - Safety Chock	2
82476	Danger - Electrocutation Hazard	2
82481	Danger - Battery/Charger Safety	1
82482	Label - Auxiliary Lowering	1

Part No.	Description	Quantity
82487	Notice - Read the Manual	2
82495	Danger - Brake Release Safety & Operating Instructions	1
82496	Danger - Max Cap 500 lbs / 227 kg	1
82502	Label - LED Diagnostic Readout	1
82560	Warning - Skin Injection Hazard	1
82562	Danger - Crushing Hazard	4
82567	Ground Control Panel	1
82656	Danger - Side Force, 445 N	1
82699	Danger - Max Cap 800 lbs / 363 kg	1
82701	Danger - Side Force, 534 N	1
97692	Label - Wheel Load, GS-2032	4
97693	Label - Wheel Load, GS-2632	4
97719	Label - Safety Arm	1
97772	Platform Control Panel	1

DECALS

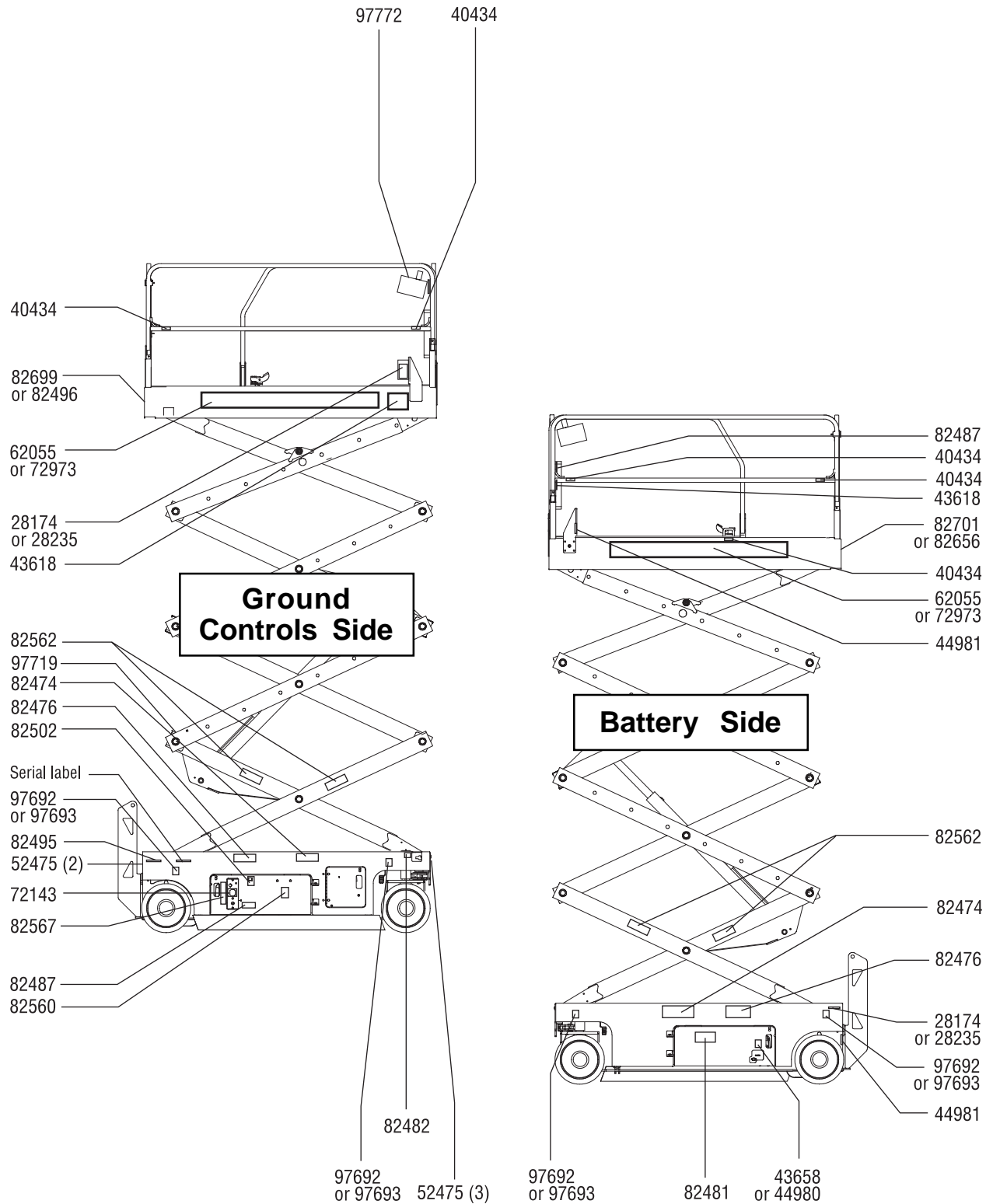

Specifications

Model	GS-2032	
Height, working maximum	26 ft	8.1 m
Height, platform maximum	20 ft	6.1 m
Height, stowed maximum Rails up - ANSI	79 ¹ / ₂ in	2.01 m
Height, stowed maximum Rails lowered	70 in	1.78 m
Height, stowed maximum Rails off	55 ¹ / ₂ in	1.41 m
Height, guard rails - ANSI, CSA and Australia	39 in	99 cm
Width	32 in	81.3 cm
Length, stowed	96 ¹ / ₄ in	2.44 m
Length, platform extended	131 ¹ / ₄ in	3.33 m
Maximum load capacity	800 lbs	363 kg
Maximum wind speed	28 mph	12.5 m/s
Wheelbase	73 in	1.85 m
Turning radius (outside)	83 ¹ / ₂ in	2.12 m
Turning radius (inside)	0 in	0 cm
Ground clearance	3 ¹ / ₂ in	8.9 cm
Ground clearance Pothole guards deployed	³ / ₄ in	1.9 cm
Weight (Machine weights vary with option configurations)	See Serial Label	
Power source	4 Batteries, 6V 225AH	
Controls	Proportional	
Platform dimensions		
Length x width	89 x 31 ¹ / ₄ in 2.26 m x 79.4 cm	
Platform extension length	39 in	99 cm
AC outlet in platform	standard	

Maximum hydraulic pressure (functions)	3500 psi	241.3 bar
--	----------	-----------

System voltage	24V	
----------------	-----	--

Tires size	15 x 5 x 11 ¹ / ₄	
------------	---	--

Airborne noise emissions Maximum sound level at normal operating workstations (A-weighted)	<70 dB	
--	--------	--

Maximum slope rating, stowed position	30% (17°)	
--	-----------	--

Maximum side slope rating, stowed position	30% (17°)	
---	-----------	--

Note: Slope rating is subject to ground conditions and adequate traction.

Drive speeds

Stowed, maximum	2.2 mph	3.5 km/h
-----------------	---------	----------

Platform raised, maximum	0.5 mph	0.8 km/h
	40 ft/54.5 sec	12.2 m/54.5 sec

Floor loading information

Tire load, maximum		
ANSI/CSA	1699 lbs	771 kg
AUS	1768 lbs	802 kg

Tire contact pressure		
ANSI/CSA	170 psi	11.95 kg/cm ² 1171 kPa
AUS	177 psi	12.44 kg/cm ² 1219 kPa

Occupied floor pressure		
ANSI/CSA	221 psf	1079 kg/m ² 10.59 kPa
AUS	243 psf	1191 kg/m ² 11.68 kPa

Note: Floor loading information is approximate and does not incorporate different option configurations. It should be used only with adequate safety factors.

Continuous improvement of our products is a Genie policy.
Product specifications are subject to change without notice or obligation.



SPECIFICATIONS

Model	GS-2632	
Height, working maximum	32 ft	9.9 m
Height, platform maximum	26 ft	7.9 m
Height, stowed maximum	84 ³ / ₄ in	2.15 m
Height, stowed maximum Rails folded	75 ¹ / ₄ in	1.91 m
Platform height, Stowed maximum	45 ¹ / ₂ in	1.16 m
Height, guard rails - ANSI, CSA and Australia	39 in	99.1 cm
Width	32 in	81.3 cm
Length, stowed	96 ¹ / ₄ in	2.44 m
Length, platform extended	131 ¹ / ₄ in	3.33 m
Maximum load capacity	500 lbs	227 kg
Maximum wind speed	28 mph	12.5 m/s
Wheelbase	73 in	1.85 m
Turning radius (outside)	83 ¹ / ₂ in	2.12 m
Turning radius (inside)	0 in	0 cm
Ground clearance	3 ¹ / ₂ in	8.9 cm
Ground clearance Pothole guards deployed	³ / ₄ in	1.9 cm
Weight	See Serial Label (Machine weights vary with option configurations)	
Power source	4 Batteries, 6V 225AH	
Controls	Proportional	
Platform dimensions		
Length x width	89 in x 31 ¹ / ₄ in 2.26 m x 79.4 cm	
Platform extension length	39 in	99 cm
AC outlet in platform	standard	

Maximum hydraulic pressure (functions)	3500 psi	241.3 bar
System voltage	24V	
Tires size	15 x 5 x 11 ¹ / ₄	
Airborne noise emissions Maximum sound level at normal operating workstations (A-weighted)	<70 dB	

**Maximum slope rating,
stowed position** 30% (17°)

**Maximum side slope rating,
stowed position** 30% (17°)

Note: Slope rating is subject to ground conditions and adequate traction.

Drive speeds

Stowed, maximum	2.2 mph	3.5 km/h
Platform raised, maximum	0.5 mph	0.8 km/h
	40 ft/54.5 sec	12.2 m/54.5 sec

Floor loading information

Tire load, maximum		
ANSI/CSA	1773 lbs	804 kg
AUS	1830 lbs	830 kg
Tire contact pressure		
ANSI/CSA	177 psi	12.48 kg/cm ² 1223 kPa
AUS	182 psi	12.87 kg/cm ² 1262 kPa
Occupied floor pressure		
ANSI/CSA	248 psf	1212 kg/m ² 11.89 kPa
AUS	243 psf	1187 kg/m ² 11.65 kPa

Note: Floor loading information is approximate and does not incorporate different option configurations. It should be used only with adequate safety factors.

Continuous improvement of our products is a Genie policy.
Product specifications are subject to change without notice or obligation.



<p>Genie Scandinavia Phone +46 31 575100 Fax +46 31 579020</p>
<p>Genie France Phone +33 (0)2 37 26 09 99 Fax +33 (0)2 37 26 09 98</p>
<p>Genie Iberica Phone +34 93 579 5042 Fax +34 93 579 5059</p>
<p>Genie Germany Phone +49 (0)4202 88520 Fax +49 (0)4202 8852-20</p>
<p>Genie U.K. Phone +44 (0)1476 584333 Fax +44 (0)1476 584334</p>
<p>Genie Mexico City Phone +52 55 5666 5242 Fax +52 55 5666 3241</p>

Genie North America
Phone 425.881.1800
Toll Free USA and Canada
800.536.1800
Fax 425.883.3475

Genie Australia Pty Ltd.
Phone +61 7 3375 1660
Fax +61 7 3375 1002

Genie China
Phone +86 21 53852570
Fax +86 21 53852569

Genie Malaysia
Phone +65 98 480 775
Fax +65 67 533 544

Genie Japan
Phone +81 3 3453 6082
Fax +81 3 3453 6083

Genie Korea
Phone +82 25 587 267
Fax +82 25 583 910

Genie Brasil
Phone +55 11 41 665 755
Fax +55 11 41 665 754

Genie Holland
Phone +31 183 581 102
Fax +31 183 581 566

Distributed By: